

**Idler stations  
hot dip galvanized**

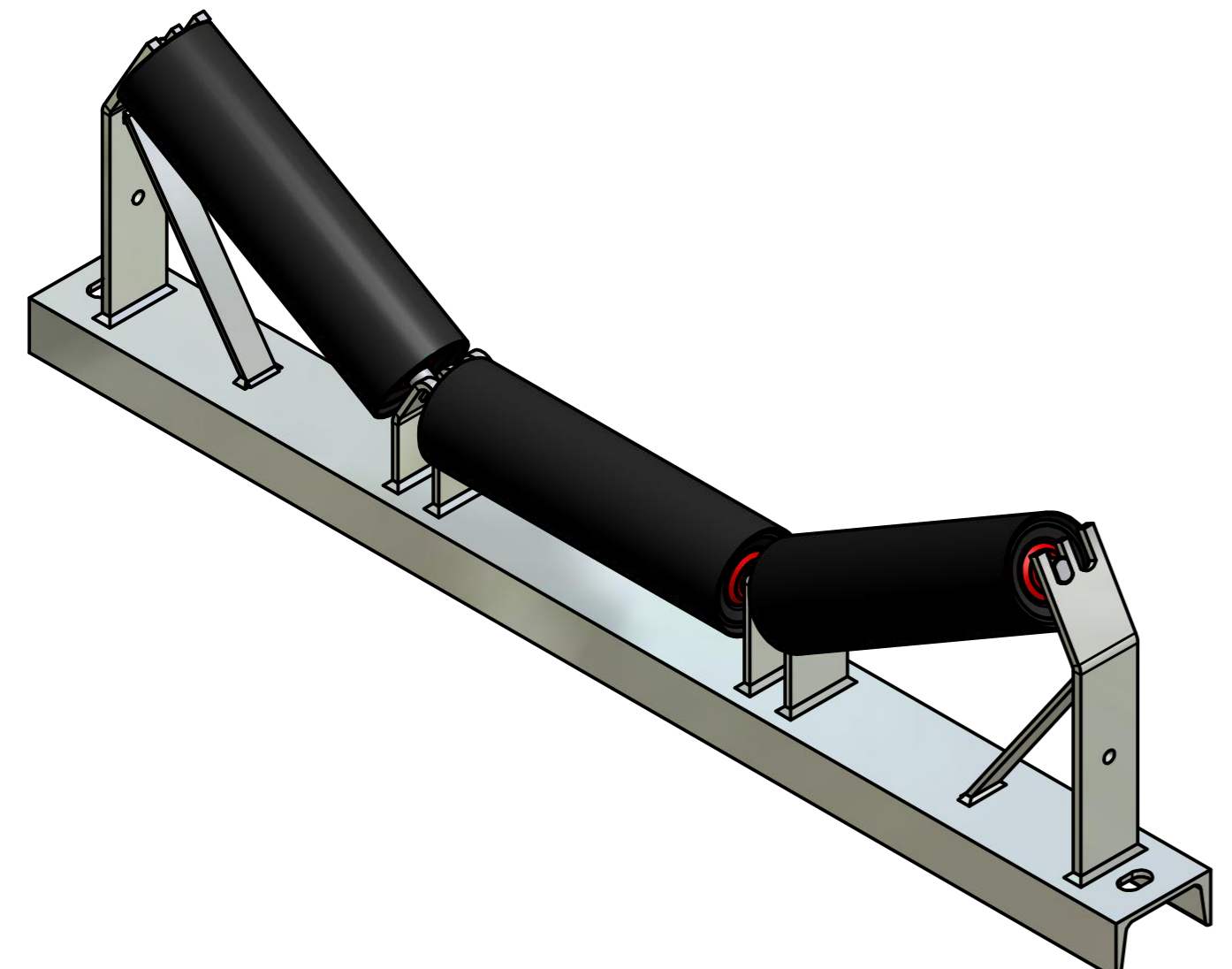

TABLE									
Article	Beltwidth	Angle	IL	H	E	FL	B	BEAM	
MBS42-0650-15Z	650	15°	258 mm	125 mm	890 mm	940 mm	14 mm	UNP-65	
MBS42-0650-30Z	650	30°	258 mm	125 mm	890 mm	940 mm	14 mm	UNP-65	
MBS42-0800-15Z	800	15°	323 mm	135 mm	1090 mm	1140 mm	18 mm	UNP-100	
MBS42-0800-30Z	800	30°	323 mm	135 mm	1090 mm	1140 mm	18 mm	UNP-100	
MBS42-1000-15Z	1000	15°	386 mm	135 mm	1290 mm	1340 mm	18 mm	UNP-100	
MBS42-1000-30Z	1000	30°	386 mm	135 mm	1290 mm	1340 mm	18 mm	UNP-100	
MBS42-1200-15Z	1200	15°	473 mm	135 mm	1530 mm	1590 mm	18 mm	UNP-100	
MBS42-1200-30Z	1200	30°	473 mm	135 mm	1530 mm	1590 mm	18 mm	UNP-100	

General tolerance +/-0,1mm  
unless differently mentioned!

© This drawing is property of MBS. This drawing and all the data on this drawing are confidential and may not be reproduced for any purpose without the written authorization of MBS.

	Date	Name	
Drawn		<b>Patrick</b>	
Checked			
Standard			
MBS bv Krommebeekpark 6, 8800 ROESELARE T +32 51 249 454 info@mbsgroup.be https://mbsgroup.be			
State	Changes	Date	Name

Idlerstations-MBS-42

1  
A2